



A D T

## FCC DoC Test Report

**Report No.:** FD151201D13

**Test Model:** UE-1008

**Series Model:** Vecow UE Series, UE-1004,  
UE-XXXXXXXXXX ("X" can be 0-9, A-Z or blank for marketing purpose)

**Received Date:** Dec. 1, 2015

**Test Date:** Dec. 4 ~ 5, 2015

**Issued Date:** Dec. 14, 2015

**Applicant:** Vecow Co., Ltd.

**Address:** 12F., No. 111, Zhongcheng Rd., Tucheng Dist., New Taipei City 23674 Taiwan  
(R. O. C.)

**Issued By:** Bureau Veritas Consumer Products Services (H.K.) Ltd., Taoyuan Branch

**Lab Address:** No. 47-2, 14th Ling, Chia Pau Vil., Lin Kou Dist., New Taipei City, Taiwan  
(R.O.C.)



LAB CODE: 200836-0



This report is for your exclusive use. Any copying or replication of this report to or for any other person or entity, or use of our name or trademark, is permitted only with our prior written permission. This report sets forth our findings solely with respect to the test samples identified herein. The results set forth in this report are not indicative or representative of the quality or characteristics of the lot from which a test sample was taken or any similar or identical product unless specifically and expressly noted. Our report includes all of the tests requested by you and the results thereof based upon the information that you provided to us. You have 60 days from date of issuance of this report to notify us of any material error or omission caused by our negligence, provided, however, that such notice shall be in writing and shall specifically address the issue you wish to raise. A failure to raise such issue within the prescribed time shall constitute your unqualified acceptance of the completeness of this report, the tests conducted and the correctness of the report contents. Unless specific mention, the uncertainty of measurement has been explicitly taken into account to declare the compliance or non-compliance to the specification. The report must not be used by the client to claim product certification, approval, or endorsement by NVLAP, NIST, or any agency of the federal government. The report must not be used by the client to claim product certification, approval, or endorsement by TAF or any government agencies.

## Table of Contents

<b>Release Control Record</b> .....	<b>3</b>
<b>1 Certificate of Conformity</b> .....	<b>4</b>
<b>2 Summary of Test Results</b> .....	<b>5</b>
2.1 Measurement Uncertainty.....	5
2.2 Modification Record.....	5
<b>3 General Information</b> .....	<b>6</b>
3.1 Features of EUT.....	6
3.2 General Description of EUT.....	6
3.3 Operating Modes of EUT and Determination of Worst Case Operating Mode.....	6
3.4 Test Program Used and Operation Descriptions .....	6
3.5 Primary Clock Frequencies of Internal Source .....	6
<b>4 Configuration and Connections with EUT</b> .....	<b>7</b>
4.1 Connection Diagram of EUT and Peripheral Devices .....	7
4.2 Configuration of Peripheral Devices and Cable Connections.....	7
<b>5 Conducted Emissions at Mains Ports</b> .....	<b>8</b>
5.1 Limits .....	8
5.2 Test Instruments.....	8
5.3 Test Arrangement.....	9
5.4 Test Results .....	10
<b>6 Radiated Emissions up to 1 GHz</b> .....	<b>12</b>
6.1 Limits .....	12
6.2 Test Instruments.....	12
6.3 Test Arrangement.....	13
6.4 Test Results .....	14
<b>7 Radiated Emissions above 1 GHz</b> .....	<b>16</b>
7.1 Limits .....	16
7.2 Test Instruments.....	17
7.3 Test Arrangement.....	18
7.4 Test Results .....	19
<b>8 Pictures of Test Arrangements</b> .....	<b>21</b>
8.1 Conducted Emissions at Mains Ports.....	21
8.2 Radiated Emissions up to 1 GHz.....	22
8.3 Radiated Emissions above 1 GHz .....	23
<b>Appendix – Information on the Testing Laboratories</b> .....	<b>24</b>



A D T

### Release Control Record

Issue No.	Description	Date Issued
FD151201D13	Original release.	Dec. 14, 2015



**1 Certificate of Conformity**

**Product:** PCI Express x4, 8 Ports/ 4 Ports USB 3.0 Expansion Card  
**Brand:** Vecow  
**Test Model:** UE-1008  
**Series Model:** Vecow UE Series, UE-1004,  
UE-XXXXXXXXXX ("X" can be 0-9, A-Z or blank for marketing purpose)  
**Sample Status:** Engineering sample  
**Applicant:** Vecow Co., Ltd.  
**Test Date:** Dec. 4 ~ 5, 2015  
**Standards:** 47 CFR FCC Part 15, Subpart B, Class B  
ICES-003:2012 Issue 5, Class B  
ANSI C63.4:2014

The above equipment has been tested by **Bureau Veritas Consumer Products Services (H.K.) Ltd., Taoyuan Branch**, and found compliance with the requirement of the above standards. The test record, data evaluation & Equipment Under Test (EUT) configurations represented herein are true and accurate accounts of the measurements of the sample's EMC characteristics under the conditions specified in this report.

**Prepared by :** Sandra Lin , **Date:** Dec. 14, 2015  
Sandra Lin / Specialist

**Approved by :** Henry Lai , **Date:** Dec. 14, 2015  
Henry Lai / Director

## 2 Summary of Test Results

47 CFR FCC Part 15, Subpart B / ICES-003:2012 Issue 5, Class B

ANSI C63.4:2014

FCC Clause	ICES-003 Clause	Test Item	Result/Remarks	Verdict
15.107	6.1	AC Power Line Conducted Emissions	Minimum passing Class B margin is -5.46 dB at 0.19297 MHz	Pass
15.109	6.2.1	Radiated Emissions up to 1 GHz	Minimum passing Class B margin is -3.39 dB at 145.20 MHz	Pass
	6.2.2	Radiated Emissions above 1 GHz	Minimum passing Class B margin is -8.79 dB at 9999.99 MHz	Pass

Note: There is no deviation to the applied test methods and requirements covered by the scope of this report.

### 2.1 Measurement Uncertainty

Where relevant, the following measurement uncertainty levels have been estimated for tests performed on the EUT:

The listed uncertainties are the worst case uncertainty for the entire range of measurement. Please note that the uncertainty values are provided for informational purposes only and are not used in determining the PASS/FAIL results.

Measurement	Frequency	Expanded Uncertainty (k=2) (±)
Conducted Emissions at mains ports	150kHz ~ 30MHz	2.78 dB
Radiated Emissions up to 1 GHz	30MHz ~ 1GHz	3.73 dB
Radiated Emissions above 1 GHz	Above 1GHz	3.36 dB

### 2.2 Modification Record

There were no modifications required for compliance.

### 3 General Information

#### 3.1 Features of EUT

The tests reported herein were performed according to the method specified by Vecow Co., Ltd., for detailed feature description, please refer to the manufacturer's specifications or user's manual.

#### 3.2 General Description of EUT

Product	PCI Express x4, 8 Ports/ 4 Ports USB 3.0 Expansion Card
Brand	Vecow
Test Model	UE-1008
Series Model	Vecow UE Series, UE-1004, UE-XXXXXXXXXX ("X" can be 0-9, A-Z or blank for marketing purpose)
Model Difference	Marketing Differentiation
Sample Status	Engineering sample
Operating Software	N/A
Power Supply Rating	DC 5.0V from PC

Note:

The EUT is a PCI Express x4, 8 Ports/ 4 Ports USB 3.0 Expansion Card with 4 independent USB controllers and up to 8 USB ports interface (including USB 3.0 & USB 2.0).

#### 3.3 Operating Modes of EUT and Determination of Worst Case Operating Mode

The EUT is consumes power from PC, which designed with AC power supply of rating 100-240Vac, 50-60Hz. For radiated emission evaluation, 230Vac/50Hz (for EN 55022), 120Vac/60Hz (for FCC Part 15) had been covered during the pre-test. The worst radiated emission data was founded at **230Vac/50Hz** and recorded in the applied test report. Then the other test items were tested at 120Vac/60Hz.

The EUT were pre-tested with USB 3.0 & USB 2.0 modes, the worst emission level was found on USB 3.0 mode. Therefore this mode was applied for final test and only its test data was recorded in this report.

#### 3.4 Test Program Used and Operation Descriptions

- a. Installed PCI Express x4, 8 Ports/ 4 Ports USB 3.0 Expansion Card (EUT) into PC.
- b. Turned on the power of all equipment.
- c. PC ran a test program to enable all functions.
- d. PC read and wrote messages from/to HDD & ext. USB HDDs via EUT.
- e. PC sent "H" messages to monitor and it displayed "H" patterns on its screen.
- f. PC sent messages to printer, and then printer printed out.
- g. PC sent messages to modem.
- h. Repeated steps c-g.

#### 3.5 Primary Clock Frequencies of Internal Source

The highest frequency generated or used within the EUT or on which the EUT operates or tunes is 5Gbps, provided by Vecow Co., Ltd., for detailed internal source, please refer to the manufacturer's specifications.

## 4 Configuration and Connections with EUT

### 4.1 Connection Diagram of EUT and Peripheral Devices

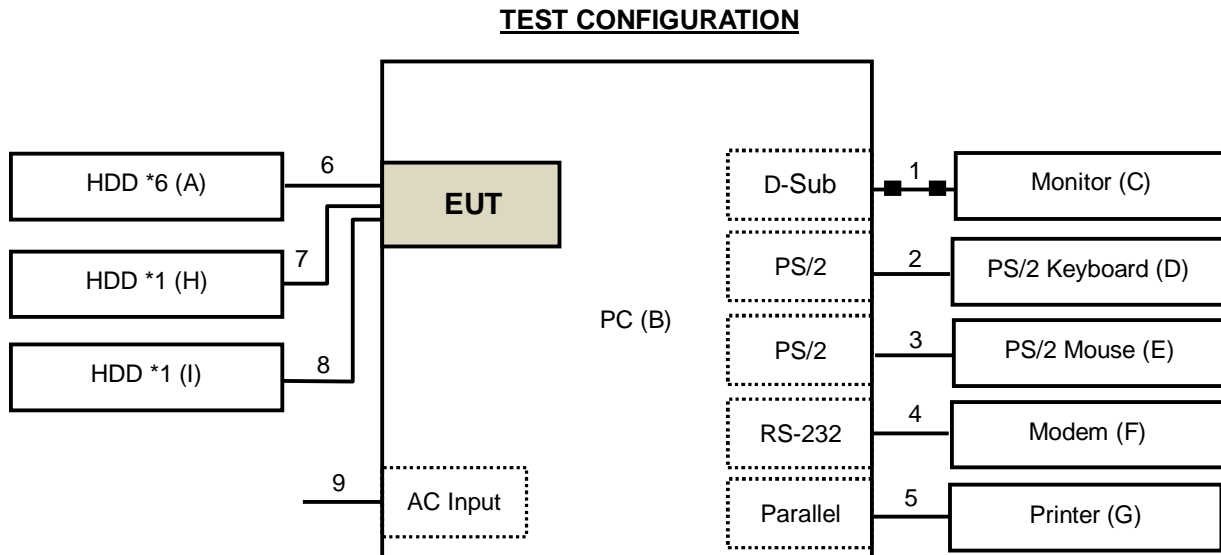

### 4.2 Configuration of Peripheral Devices and Cable Connections

ID	Product	Brand	Model No.	Serial No.	FCC ID	Remarks
A.	USB 3.0 Hard Disk	WD	WDBACY5000ABL-PESN	WX11E91JE773	FCC DoC Approved	Provided by Lab
	USB 3.0 Hard Disk	WD	WDBACY5000ABL-PESN	WXG1A91A9208	FCC DoC Approved	Provided by Lab
	USB 3.0 Hard Disk	WD	WDBACY5000ABL-PESN	WX71E91FXHL1	FCC DoC Approved	Provided by Lab
	USB 3.0 Hard Disk	WD	WDBACY5000ABL-PESN	WX61A9115393	FCC DoC Approved	Provided by Lab
	USB 3.0 Hard Disk	WD	WDBACY5000ABL-PESN	WXA1A81U3670	FCC DoC Approved	Provided by Lab
	USB 3.0 Hard Disk	WD	WDBACY5000ABL-PESN	WXH1A91A6872	FCC DoC Approved	Provided by Lab
B.	PC	HP	DX-7400MT	SGH8460H2S	FCC DoC Approved	Provided by Lab
C.	24" LCD Monitor	DELL	U2410	CN082WXD728720CC0 KDL	FCC DoC Approved	Provided by Lab
D.	PS/2 Keyboard	HP	KB-0316	BC3520GVBWT0XZ	FCC DoC Approved	Provided by Lab
E.	PS/2 Mouse	BTC	M851	N/A	E5XMSM860	Provided by Lab
F.	Modem	ACEEX	1414	980020506	IFAXDM1414	Provided by Lab
G.	Printer	EPSON	LQ-300+II	G88Y058151	FCC DoC Approved	Provided by Lab
H.	USB 3.0 Hard Disk	WD	WDBACY5000ABL-PESN	WXD1E91KNHR8	FCC DoC Approved	Provided by Lab
I.	External Hard Disk	Seagate	SRD00F2	NA4M1SB3	FCC DoC Approved	Provided by Lab

Note: All power cords of the above support units are non-shielded (1.8m).

ID	Descriptions	Qty.	Length (m)	Shielding (Yes/No)	Cores (Qty.)	Remarks
1.	D-SUB cable	1	1.8	Y	2	Provided by Lab
2.	PS/2 cable	1	1.5	Y	0	Provided by Lab
3.	PS/2 cable	1	1.2	Y	0	Provided by Lab
4.	RS-232 cable	1	1.8	Y	0	Provided by Lab
5.	Parallel cable	1	1.8	Y	0	Provided by Lab
6.	USB cable	6	0.4	Y	0	Provided by Lab
7.	USB cable	1	1.2	Y	0	Provided by Lab
8.	USB cable	1	1.2	Y	0	Provided by Lab
9.	AC power cable	1	1.8	N	0	Provided by Lab

Note: The core(s) is(are) originally attached to the cable(s).

## 5 Conducted Emissions at Mains Ports

### 5.1 Limits

Frequency (MHz)	Class A (dBuV)		Class B (dBuV)	
	Quasi-peak	Average	Quasi-peak	Average
0.15 - 0.5	79	66	66 - 56	56 - 46
0.50 - 5.0	73	60	56	46
5.0 - 30.0	73	60	60	50

Notes: 1. The lower limit shall apply at the transition frequencies.  
 2. The limit decreases linearly with the logarithm of the frequency in the range of 0.15 to 0.50 MHz.

### 5.2 Test Instruments

Description & Manufacturer	Model No.	Serial No.	Cal. Date	Cal. Due
ROHDE & SCHWARZ TEST RECEIVER	ESCS 30	100290	Dec. 27, 2014	Dec. 26, 2015
ROHDE & SCHWARZ Artificial Mains Network (for EUT)	ENV 216	101196	Apr. 17, 2015	Apr. 16, 2016
LISN With Adapter (for EUT)	AD10	C09Ada-001	Apr. 17, 2015	Apr. 16, 2016
ROHDE & SCHWARZ Artificial Mains Network (for peripherals)	ESH3-Z5	847265/023	Oct. 21, 2015	Oct. 20, 2016
SCHWARZBECK Artificial Mains Network (For EUT)	NNLK8129	8129229	May 06, 2015	May 05, 2016
Software	Cond_V7.3.7	NA	NA	NA
RF cable (JYEBAO) With 10dB PAD	5D-FB	Cable-C09.01	Feb. 24, 2015	Feb. 23, 2016
SUHNER Terminator (For ROHDE & SCHWARZ LISN)	65BNC-5001	E1-010789	May 19, 2015	May 18, 2016
ROHDE & SCHWARZ Artificial Mains Network (For TV EUT)	ESH3-Z5	100220	Nov. 13, 2015	Nov. 12, 2016
LISN With Adapter (for TV EUT)	100220	N/A	Nov. 13, 2015	Nov. 12, 2016

Notes: 1. The calibration interval of the above test instruments is 12 months and the calibrations are traceable to NML/ROC and NIST/USA.  
 2. The test was performed in Shielded Room No. 9.  
 3. The VCCI Site Registration No. C-1312.  
 4. Tested Date: Dec. 4, 2015.



### 5.3 Test Arrangement

- The EUT was placed 0.4 meters from the conducting wall of the shielded room with EUT being connected to the power mains through a line impedance stabilization network (LISN). Other support units were connected to the power mains through another LISN. The two LISNs provide 50 Ohm/ 50uH of coupling impedance for the measuring instrument.
- Both lines of the power mains connected to the EUT were checked for maximum conducted interference.
- The test results of conducted emissions at mains ports are recorded of six worst margins for quasi-peak (mandatory) [and average (if necessary)] values against the limits at frequencies of interest unless the margin is 20 dB or greater.

Note: The resolution bandwidth and video bandwidth of test receiver is 9kHz for quasi-peak detection (QP) and average detection (AV) at frequency 0.15MHz-30MHz.

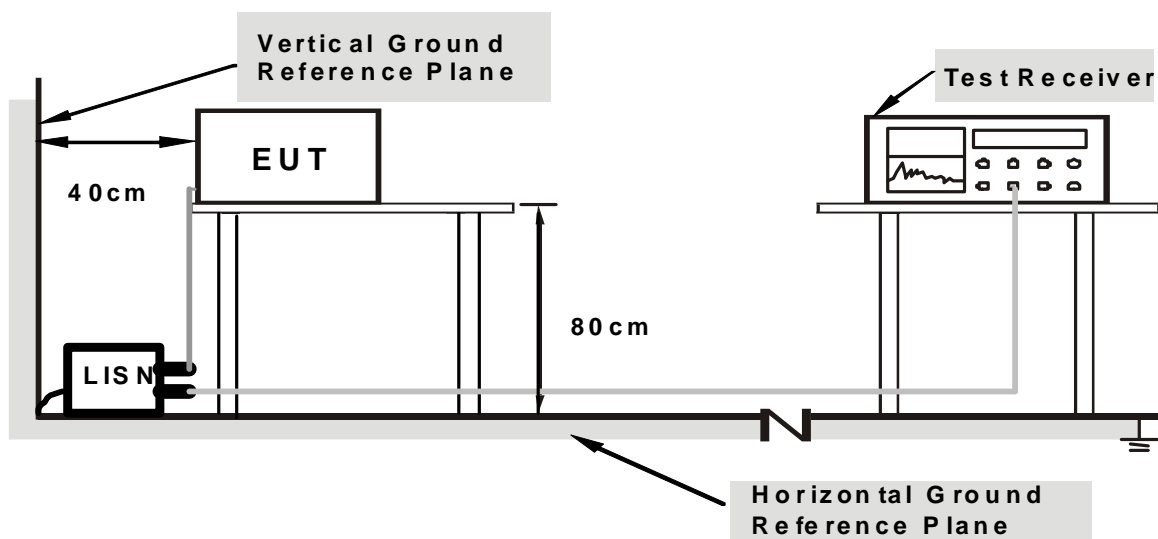

**Note: Support units were connected to second LISN.**

For the actual test configuration, please refer to the related item – Photographs of the Test Configuration.

### 5.4 Test Results

<b>Frequency Range</b>	150kHz ~ 30MHz	<b>Detector Function &amp; Resolution Bandwidth</b>	Quasi-Peak (QP) / Average (AV), 9kHz
<b>Input Power &lt;From system&gt;</b>	120Vac, 60Hz	<b>Environmental Conditions</b>	18°C, 75%RH
<b>Tested by</b>	Vincent Lin		
<b>Test Mode</b>	With system		

Phase Of Power : Line (L)										
No	Frequency (MHz)	Correction Factor (dB)	Reading Value (dBuV)		Emission Level (dBuV)		Limit (dBuV)		Margin (dB)	
			Q.P.	AV.	Q.P.	AV.	Q.P.	AV.	Q.P.	AV.
1	0.19297	9.71	41.54	38.59	51.25	48.30	63.91	53.91	-12.66	-5.61
2	0.25802	9.72	28.83	26.97	38.55	36.69	61.49	51.49	-22.94	-14.80
3	0.81797	9.79	20.90	17.53	30.69	27.32	56.00	46.00	-25.31	-18.68
4	2.32813	9.87	23.91	19.55	33.78	29.42	56.00	46.00	-22.22	-16.58
5	10.50781	9.99	20.87	15.73	30.86	25.72	60.00	50.00	-29.14	-24.28
6	23.75012	10.06	36.03	26.49	46.09	36.55	60.00	50.00	-13.91	-13.45

**Remarks:**

1. Q.P. and AV. are abbreviations of quasi-peak and average individually.
2. The emission levels of other frequencies were very low against the limit.
3. Margin value = Emission level – Limit value
4. Correction factor = Insertion loss + Cable loss
5. Emission Level = Correction Factor + Reading Value

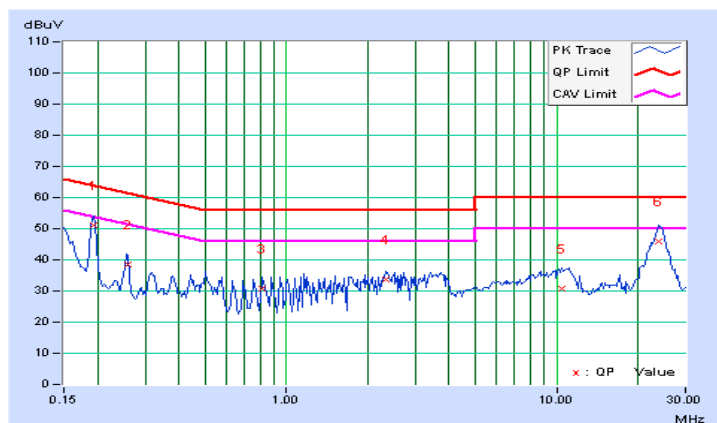

<b>Frequency Range</b>	150kHz ~ 30MHz	<b>Detector Function &amp; Resolution Bandwidth</b>	Quasi-Peak (QP) / Average (AV), 9kHz
<b>Input Power &lt;From system&gt;</b>	120Vac, 60Hz	<b>Environmental Conditions</b>	18°C, 75%RH
<b>Tested by</b>	Vincent Lin		
<b>Test Mode</b>	With system		

Phase Of Power : Neutral (N)										
No	Frequency (MHz)	Correction Factor (dB)	Reading Value (dBuV)		Emission Level (dBuV)		Limit (dBuV)		Margin (dB)	
			Q.P.	AV.	Q.P.	AV.	Q.P.	AV.	Q.P.	AV.
1	0.19297	9.68	41.78	38.77	51.46	48.45	63.91	53.91	-12.45	-5.46
2	0.25802	9.69	28.90	25.97	38.59	35.66	61.49	51.49	-22.91	-15.84
3	0.62919	9.73	20.42	17.15	30.15	26.88	56.00	46.00	-25.85	-19.12
4	1.16271	9.78	22.20	20.25	31.98	30.03	56.00	46.00	-24.02	-15.97
5	3.77344	9.86	22.30	17.49	32.16	27.35	56.00	46.00	-23.84	-18.65
6	24.25236	10.09	32.40	21.42	42.49	31.51	60.00	50.00	-17.51	-18.49

**Remarks:**

1. Q.P. and AV. are abbreviations of quasi-peak and average individually.
2. The emission levels of other frequencies were very low against the limit.
3. Margin value = Emission level – Limit value
4. Correction factor = Insertion loss + Cable loss
5. Emission Level = Correction Factor + Reading Value

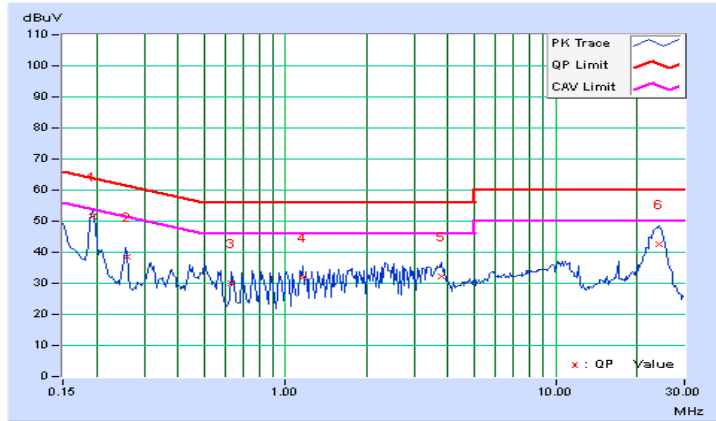

## 6 Radiated Emissions up to 1 GHz

### 6.1 Limits

Emissions radiated outside of the specified bands, shall be according to the general radiated limits as following:

Radiated Emissions Limits at 10 meters (dB $\mu$ V/m)				
Frequencies (MHz)	FCC 15B / ICES-003, Class A	FCC 15B / ICES-003, Class B	CISPR 22, Class A	CISPR 22, Class B
30-88	39	29.5	40	30
88-216	43.5	33.1		
216-230	46.4	35.6		
230-960				
960-1000	49.5	43.5	47	37

Radiated Emissions Limits at 3 meters (dB $\mu$ V/m)				
Frequencies (MHz)	FCC 15B / ICES-003, Class A	FCC 15B / ICES-003, Class B	CISPR 22, Class A	CISPR 22, Class B
30-88	49.5	40	50.5	40.5
88-216	54	43.5		
216-230	56.9	46		
230-960				
960-1000	60	54	57.5	47.5

- Notes:
1. The lower limit shall apply at the transition frequencies.
  2. Emission level (dB $\mu$ V/m) = 20 log Emission level (uV/m).
  3. QP detector shall be applied if not specified.

### 6.2 Test Instruments

Description & Manufacturer	Model No.	Serial No.	Cal. Date	Cal. Due
ROHDE & SCHWARZ TEST RECEIVER	ESCI	100744	Apr. 24, 2015	Apr. 23, 2016
Schaffner BILOG Antenna	CBL6111D	22270	Feb. 03, 2015	Feb. 02, 2016
CT Turn Table	TT100	CT-080	NA	NA
CT Tower	AT100	CT-080	NA	NA
Software	Radiated_V7.6.15.9.4	NA	NA	NA
ANRITSU RF Switches	MP59B	N/A	Nov. 20, 2015	Nov. 19, 2016
WOKEN RF cable	8D	CABLE-ST3-01	Nov. 20, 2015	Nov. 19, 2016

- Notes:
1. The calibration interval of the above test instruments is 12 months and the calibrations are traceable to NML/ROC and NIST/USA.
  2. The test was performed in Open Site No. 3.
  3. The VCCI Site Registration No. is R-269.
  4. The FCC Site Registration No. 90424.
  5. Tested Date: Dec. 4, 2015.

### 6.3 Test Arrangement

- The EUT was placed on the top of a rotating table 0.8 meters above the ground at an accredited test facility. The table was rotated 360 degrees to determine the position of the highest radiation.
- The EUT was set 10 meters away from the interference-receiving antenna, which was mounted on the top of a variable-height antenna tower.
- The antenna is a broadband antenna, and its height is varied from one meter to four meters above the ground to determine the maximum value of the field strength. Both horizontal and vertical polarizations of the antenna are set to make the measurement.
- For each suspected emission, the EUT was arranged to its worst case and then the antenna was tuned to heights from 1 meter to 4 meters and the rotatable table was turned from 0 degrees to 360 degrees to find the maximum reading.
- The test-receiver system was set to quasi-peak detect function and specified bandwidth with maximum hold mode when the test frequency is up to 1 GHz.

Note: The resolution bandwidth and video bandwidth of test receiver/spectrum analyzer is 120kHz for quasi-peak detection (QP) at frequency up to 1GHz.

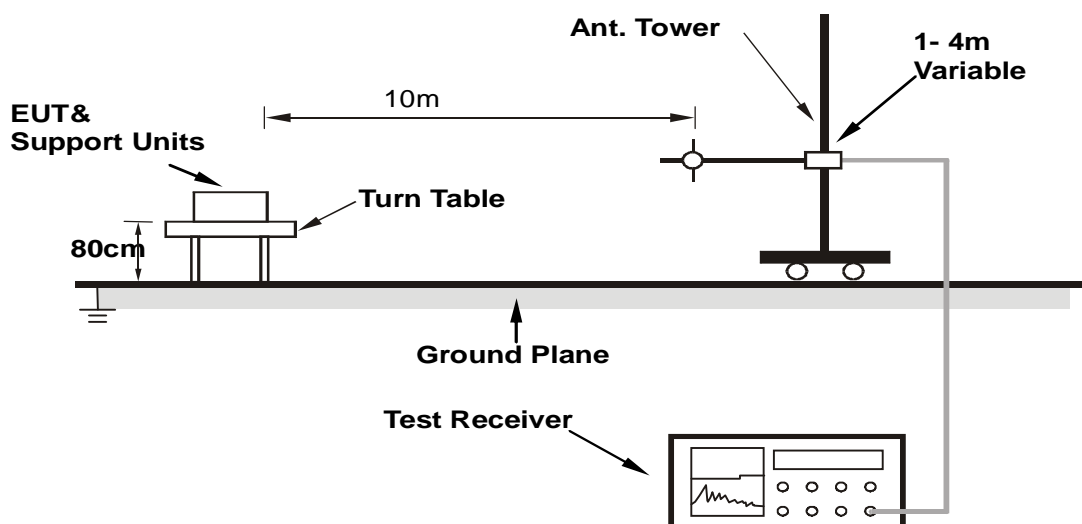

For the actual test configuration, please refer to the related item – Photographs of the Test Configuration.

### 6.4 Test Results

<b>Frequency Range</b>	30MHz ~ 1GHz	<b>Detector Function &amp; Resolution Bandwidth</b>	Quasi-Peak (QP), 120kHz
<b>Tested by</b>	Chin Wen Wang	<b>Environmental Conditions</b>	20°C, 64%RH
<b>Test Mode</b>	With system		

**Antenna Polarity & Test Distance : Horizontal at 10 m**

No	Frequency (MHz)	Emission Level (dBuV/m)	Limit (dBuV/m)	Margin (dB)	Antenna Height (m)	Table Angle (Degree)	Raw Value (dBuV)	Correction Factor (dB/m)
1	78.40	21.26 QP	30.00	-8.74	4.00 H	277	12.90	8.36
2	126.75	22.33 QP	30.00	-7.67	4.00 H	134	8.88	13.45
3	178.40	26.28 QP	30.00	-3.72	4.00 H	1	14.96	11.32
4	200.05	26.20 QP	30.00	-3.80	4.00 H	2	14.77	11.43
5	218.15	25.01 QP	30.00	-4.99	4.00 H	249	13.18	11.83
6	280.90	33.28 QP	37.00	-3.72	2.82 H	241	17.62	15.66
7	532.75	30.38 QP	37.00	-6.62	1.66 H	330	8.27	22.11
8	750.25	31.17 QP	37.00	-5.83	1.32 H	329	4.74	26.43
9	810.25	29.77 QP	37.00	-7.23	1.18 H	16	3.25	26.52

Remarks:

1. Emission Level(dBuV/m) = Raw Value(dBuV) + Correction Factor(dB/m)
2. Correction Factor(dB/m) = Antenna Factor (dB/m) + Cable Factor (dB) – Pre-Amplifier Factor (dB)
3. The other emission levels were very low against the limit.
4. Margin value = Emission level – Limit value

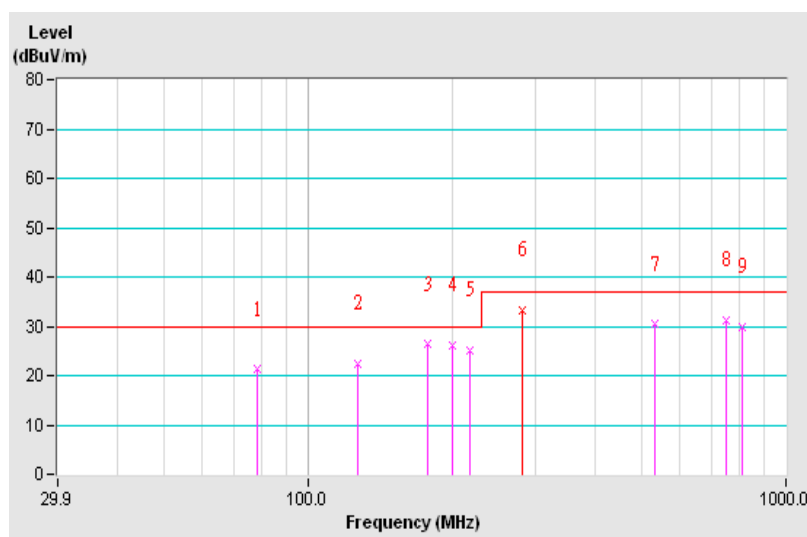

<b>Frequency Range</b>	30MHz ~ 1GHz	<b>Detector Function &amp; Resolution Bandwidth</b>	Quasi-Peak (QP), 120kHz
<b>Tested by</b>	Chin Wen Wang	<b>Environmental Conditions</b>	20°C, 64%RH
<b>Test Mode</b>	With system		

**Antenna Polarity & Test Distance : Vertical at 10 m**

No	Frequency (MHz)	Emission Level (dBuV/m)	Limit (dBuV/m)	Margin (dB)	Antenna Height (m)	Table Angle (Degree)	Raw Value (dBuV)	Correction Factor (dB/m)
1	59.40	24.02 QP	30.00	-5.98	1.23 V	75	16.78	7.24
2	85.45	23.59 QP	30.00	-6.41	1.65 V	270	14.05	9.54
3	114.10	22.80 QP	30.00	-7.20	1.00 V	236	9.53	13.27
<b>4</b>	<b>145.20</b>	<b>26.61 QP</b>	<b>30.00</b>	<b>-3.39</b>	<b>1.00 V</b>	<b>78</b>	<b>13.23</b>	<b>13.38</b>
5	155.95	22.17 QP	30.00	-7.83	1.00 V	258	9.19	12.98
6	200.05	22.41 QP	30.00	-7.59	1.00 V	121	10.98	11.43
7	281.00	31.61 QP	37.00	-5.39	1.00 V	230	15.95	15.66
8	652.00	29.15 QP	37.00	-7.85	2.03 V	160	4.72	24.43
9	750.25	28.55 QP	37.00	-8.45	1.72 V	285	2.12	26.43
10	987.25	31.04 QP	37.00	-5.96	2.86 V	196	1.37	29.67

Remarks:

1. Emission Level(dBuV/m) = Raw Value(dBuV) + Correction Factor(dB/m)
2. Correction Factor(dB/m) = Antenna Factor (dB/m) + Cable Factor (dB) – Pre-Amplifier Factor (dB)
3. The other emission levels were very low against the limit.
4. Margin value = Emission level – Limit value

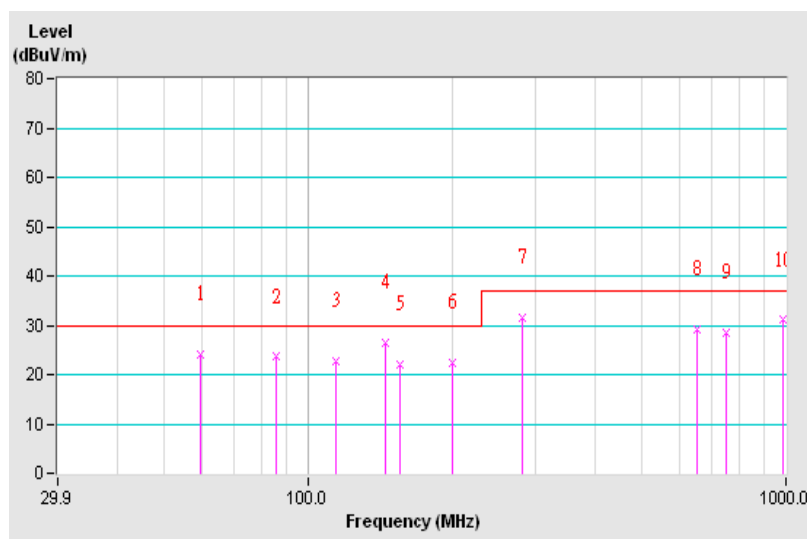

## 7 Radiated Emissions above 1 GHz

### 7.1 Limits

Emissions radiated outside of the specified bands, shall be according to the general radiated limits as following:

Radiated Emissions Limits at 10 meters (dB $\mu$ V/m)				
Frequencies (MHz)	FCC 15B / ICES-003, Class A	FCC 15B / ICES-003, Class B	CISPR 22, Class A	CISPR 22, Class B
1000-3000	Avg: 49.5	Avg: 43.5	Not defined	Not defined
Above 3000	Peak: 69.5	Peak: 63.5	Not defined	Not defined

Radiated Emissions Limits at 3 meters (dB $\mu$ V/m)				
Frequencies (MHz)	FCC 15B / ICES-003, Class A	FCC 15B / ICES-003, Class B	CISPR 22, Class A	CISPR 22, Class B
1000-3000	Avg: 60	Avg: 54	Avg: 56 Peak: 76	Avg: 50 Peak: 70
Above 3000	Peak: 80	Peak: 74	Avg: 60 Peak: 80	Avg: 54 Peak: 74

- Notes:
1. The lower limit shall apply at the transition frequencies.
  2. Emission level (dB $\mu$ V/m) = 20 log Emission level (uV/m).
  3. As shown in 15.35(b), for frequencies above 1000MHz, the field strength limits are based on average detector, however, the peak field strength of any emission shall not exceed the maximum permitted average limits, specified above by more than 20dB under any condition of modulation.

#### Frequency Range (For unintentional radiators)

Highest frequency generated or used in the device or on which the device operates or tunes (MHz)	Upper frequency of measurement range (MHz)
Below 1.705	30
1.705-108	1000
108-500	2000
500-1000	5000
Above 1000	5th harmonic of the highest frequency or 40GHz, whichever is lower





## 7.2 Test Instruments

Description & Manufacturer	Model No.	Serial No.	Cal. Date	Cal. Due
Agilent Spectrum	E4446A	MY51100009	May 30, 2015	May 29, 2016
Agilent Test Receiver	N9038A	MY51210137	Jul. 13, 2015	Jul. 12, 2016
Agilent Preamplifier	8449B	3008A01292	Feb. 26, 2015	Feb. 25, 2016
MITEQ Preamplifier	AMF-6F-260400-33-8P	892164	Mar. 01, 2015	Feb. 28, 2016
EMCI Preamplifier	EMC184045B	980235	Mar. 01, 2015	Feb. 28, 2016
Schwarzbeck Horn Antenna	BBHA-9170	212	Feb. 09, 2015	Feb. 08, 2016
EMCO Horn Antenna	3115	6714	Feb. 06, 2015	Feb. 05, 2016
Max Full. Turn Table	MF7802	MF780208216	NA	NA
Software	Radiated_V8.7.07	NA	NA	NA
SUHNER RF cable With 4dB PAD	SF106-18	Cable-CH10	Aug. 15, 2015	Aug. 14, 2016
SUHNER RF cable With 3dB PAD	SF102	Cable-CH8-3.6m	Aug. 15, 2015	Aug. 14, 2016

- Notes:
1. The calibration interval of the above test instruments is 12 months and the calibrations are traceable to NML/ROC and NIST/USA.
  2. The test was performed in Chamber No. 10.
  3. The Industry Canada Reference No. IC 7450E-11.
  4. The VCCI Site Registration No. G-427
  5. The FCC Site Registration No. 367016
  6. Tested Date: Dec. 5, 2015.

### 7.3 Test Arrangement

- The EUT was placed on the top of a rotating table 0.8 meters above the ground at an accredited chamber room. The table was rotated 360 degrees to determine the position of the highest radiation.
- The EUT was set 3 meters away from the interference-receiving antenna, which was mounted on the top of a variable-height antenna tower.
- The height of antenna can be varied from one meter to four meters, the height of adjustment depends on the EUT height and the antenna 3dB beamwidth both, to detect the maximum value of the field strength. Both horizontal and vertical polarizations of the antenna are set to make the measurement.
- For each suspected emission, the EUT was arranged to its worst case and then the antenna was tuned to heights and the rotatable table was turned from 0 degrees to 360 degrees to find the maximum reading.
- The spectrum analyzer system was set to peak and average detect function and specified bandwidth with maximum hold mode when the test frequency is above 1 GHz.

Note: The resolution bandwidth of test receiver/spectrum analyzer is 1MHz and video bandwidth is 3MHz for Peak detection (PK) at frequency above 1GHz. The resolution bandwidth of test receiver/spectrum analyzer is 1 MHz for Average detection (AV) at frequency above 1GHz.

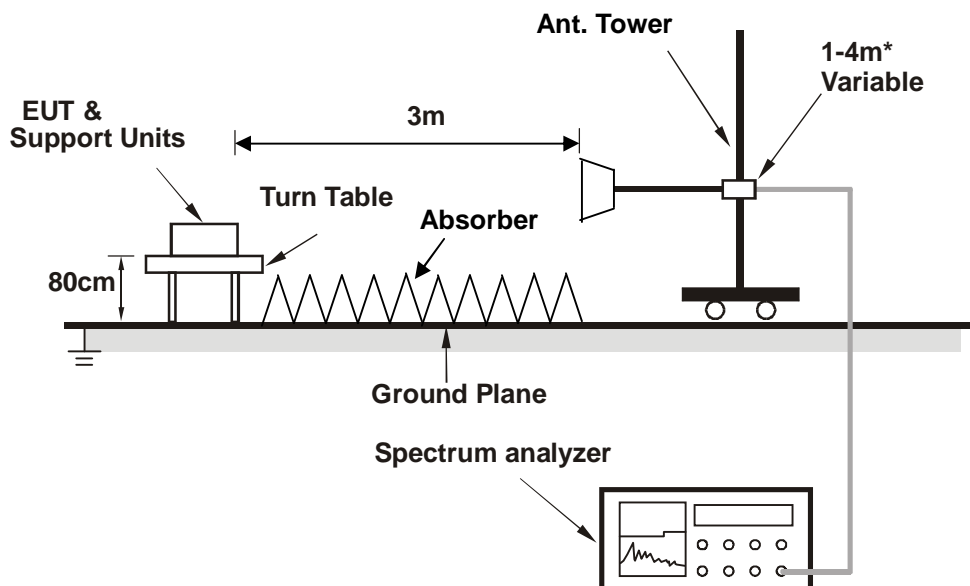

\* :depends on the EUT height and the antenna 3dB beamwidth both.

For the actual test configuration, please refer to the related item – Photographs of the Test Configuration.

### 7.4 Test Results

<b>Frequency Range</b>	1GHz ~ 25GHz	<b>Detector Function &amp; Resolution Bandwidth</b>	Peak (PK) / Average (AV), 1MHz
<b>Tested by</b>	Vincent Lin	<b>Environmental Conditions</b>	18°C, 75%RH
<b>Test Mode</b>	With system		

**Antenna Polarity & Test Distance : Horizontal at 3 m**

No	Frequency (MHz)	Emission Level (dBuV/m)	Limit (dBuV/m)	Margin (dB)	Antenna Height (m)	Table Angle (Degree)	Raw Value (dBuV)	Correction Factor (dB/m)
1	1379.95	57.55 PK	74.00	-16.45	1.74 H	191	62.16	-4.61
2	1379.95	36.09 AV	54.00	-17.91	1.74 H	191	40.70	-4.61
3	1999.92	56.13 PK	74.00	-17.87	1.28 H	0	58.22	-2.09
4	1999.92	35.48 AV	54.00	-18.52	1.28 H	0	37.57	-2.09
5	2999.86	61.52 PK	74.00	-12.48	1.18 H	147	60.08	1.44
6	2999.86	38.09 AV	54.00	-15.91	1.18 H	147	36.65	1.44
7	4988.44	52.94 PK	74.00	-21.06	1.80 H	329	47.38	5.56
8	4988.44	35.76 AV	54.00	-18.24	1.80 H	329	30.20	5.56
9	6000.22	49.71 PK	74.00	-24.29	2.76 H	165	42.81	6.90
10	6000.22	37.76 AV	54.00	-16.24	2.76 H	165	30.86	6.90
11	7500.18	58.85 PK	74.00	-15.15	2.46 H	261	48.80	10.05
12	7500.18	38.77 AV	54.00	-15.23	2.46 H	261	28.72	10.05

Remarks:

1. Emission Level(dBuV/m) = Raw Value(dBuV) + Correction Factor(dB/m)
2. Correction Factor(dB/m) = Antenna Factor (dB/m) + Cable Factor (dB) – Pre-Amplifier Factor (dB)
3. The other emission levels were very low against the limit.
4. Margin value = Emission level – Limit value

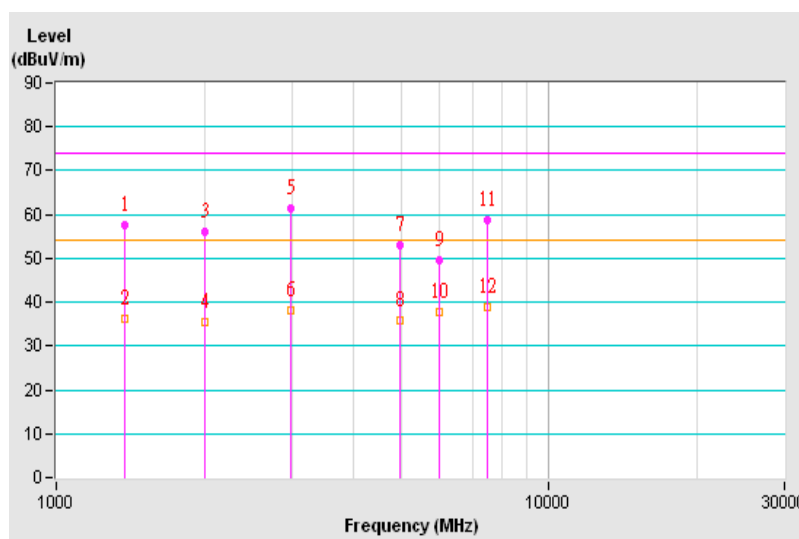



<b>Frequency Range</b>	1GHz ~ 25GHz	<b>Detector Function &amp; Resolution Bandwidth</b>	Peak (PK) / Average (AV), 1MHz
<b>Tested by</b>	Vincent Lin	<b>Environmental Conditions</b>	18°C, 75%RH
<b>Test Mode</b>	With system		

Antenna Polarity & Test Distance : Vertical at 3 m								
No	Frequency (MHz)	Emission Level (dBuV/m)	Limit (dBuV/m)	Margin (dB)	Antenna Height (m)	Table Angle (Degree)	Raw Value (dBuV)	Correction Factor (dB/m)
1	1380.64	57.03 PK	74.00	-16.97	2.06 V	169	61.64	-4.61
2	1380.64	34.86 AV	54.00	-19.14	2.06 V	169	39.47	-4.61
3	1523.38	55.24 PK	74.00	-18.76	2.10 V	182	59.43	-4.19
4	1523.38	32.25 AV	54.00	-21.75	2.10 V	182	36.44	-4.19
5	1991.25	55.69 PK	74.00	-18.31	1.80 V	253	57.80	-2.11
6	1991.25	30.60 AV	54.00	-23.40	1.80 V	253	32.71	-2.11
7	2999.48	61.21 PK	74.00	-12.79	1.54 V	126	59.77	1.44
8	2999.48	35.41 AV	54.00	-18.59	1.54 V	126	33.97	1.44
9	4999.94	52.12 PK	74.00	-21.88	1.12 V	178	46.55	5.57
10	4999.94	42.21 AV	54.00	-11.79	1.12 V	178	36.64	5.57
11	6000.43	51.89 PK	74.00	-22.11	2.23 V	347	44.99	6.90
12	6000.43	39.24 AV	54.00	-14.76	2.23 V	347	32.34	6.90
13	7000.18	58.50 PK	74.00	-15.50	1.25 V	181	49.71	8.79
14	7000.18	37.25 AV	54.00	-16.75	1.25 V	181	28.46	8.79
15	7500.31	58.91 PK	74.00	-15.09	1.64 V	120	48.86	10.05
16	7500.31	39.27 AV	54.00	-14.73	1.64 V	120	29.22	10.05
17	9999.99	56.27 PK	74.00	-17.73	1.00 V	172	44.85	11.42
<b>18</b>	<b>9999.99</b>	<b>45.21 AV</b>	<b>54.00</b>	<b>-8.79</b>	<b>1.00 V</b>	<b>172</b>	<b>33.79</b>	<b>11.42</b>

- Remarks: 1. Emission Level(dBuV/m) = Raw Value(dBuV) + Correction Factor(dB/m)  
 2. Correction Factor(dB/m) = Antenna Factor (dB/m) + Cable Factor (dB) – Pre-Amplifier Factor (dB)  
 3. The other emission levels were very low against the limit.  
 4. Margin value = Emission level – Limit value

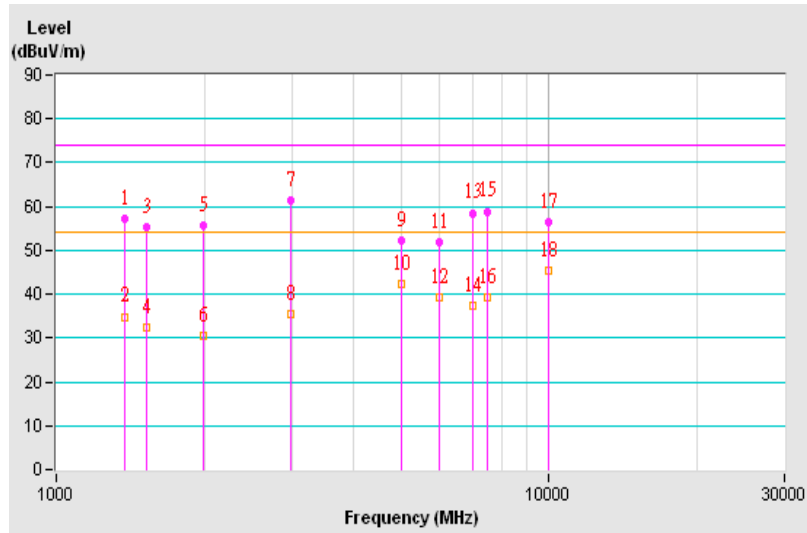

## 8 Pictures of Test Arrangements

### 8.1 Conducted Emissions at Mains Ports



## 8.2 Radiated Emissions up to 1 GHz



### 8.3 Radiated Emissions above 1 GHz



## Appendix – Information on the Testing Laboratories

We, Bureau Veritas Consumer Products Services (H.K.) Ltd., Taoyuan Branch, were founded in 1988 to provide our best service in EMC, Radio, Telecom and Safety consultation. Our laboratories are accredited and approved according to ISO/IEC 17025.

If you have any comments, please feel free to contact us at the following:

**Linko EMC/RF Lab**

Tel: 886-2-26052180

Fax: 886-2-26051924

**Hsin Chu EMC/RF/Telecom Lab**

Tel: 886-3-6668565

Fax: 886-3-6668323

**Hwa Ya EMC/RF/Safety Lab**

Tel: 886-3-3183232

Fax: 886-3-3270892

**Email:** [service.adt@tw.bureauveritas.com](mailto:service.adt@tw.bureauveritas.com)

**Web Site:** [www.bureauveritas-adt.com](http://www.bureauveritas-adt.com)

The address and road map of all our labs can be found in our web site also.

--- END ---